

Scan DSA 12



Congratulations on your new Scan built-in stove

You have purchased a product by one of Europe's leading manufacturer's of wood-burning stoves, and we are sure that you will have years of pleasure with your purchase. To make the best possible use of your built- in stove, it is important that you follow our advice and instructions.

Please read this Assembly- and instructions manual before you start to assemble your built-in stove.

Product registration number

Please indicate the product registration number at any enquiry

Table of contents

Technical data	3
Installation	
Safety	
Technical dimensions and data	
Dimension sketch for Scan DSA 12	
Type plate	
Additional accessories	
Product registration number	
Assembly	6
Dismantling	
Load-bearing foundation	
Floor plate	
Convection air	
Distance to furniture	
Installation in connection with flammable materials	
Positioning near non-flammable materials	
Trims and doors	
Existing chimney and pre-fabricated element chimney	
Connection between stove and steel chimney	
Requirements for chimney	
Adjustable supporting legs	
Door lock	
Fresh air intake	
Closed combustion system	
Fitting of accessories	12
Fitting the convection adaptors	
Mounting of convection grate	
Instruction for use	14
CB technique	
Lower baffle plate	
Primary air	
Secondary air	
Ash drawer	
Instructions for heating	15
Lighting	
Handling fuel	
Maintenance	17
Troubleshooting	19

Installation

The house owner is responsible for ensuring that all necessary national and local safety measures are observed during installation and fitting and also responsible for observing the fitting and operating instructions detailed in this manual.

When you install any kind of fireplace or stove, you must inform the local authorities. You are also responsible for calling in a chimney sweep to inspect and authorize the installation.

To ensure best-possible functionality and safety for your installation, we advise you to call a professional fitter. Our Scan Dealer will be able to recommend a qualified fitter in your area. For information on Scan Dealers, please go to www.scan.dk.

Safety

Any changes made to the product by the dealer, installer or user could result in the product and safety functions not functioning as intended. The same applies to the fitting of accessories or extra equipment not supplied by Scan A/S. This could also be the case if parts that are necessary for the operation and safety of the stove are dismantled or removed.

Technical data and dimensions

Materials:	steel plate, cast iron, galvanised sheet, skamol
Surface treatment:	Senotherm
Max. wood length:	45 cm
Flue outlet:	Top
Weight:	210 kg
Connecting piece internal diameter:	175 mm
Connecting piece external diameter:	179 mm
Approval type:	Intermittent fuelling

Test in compliance with EN 13229

CO Emission at 13% O ₂ :	0,09%	1142 mg/Nm ³
Dust @ 13% O ₂ :		31 mg/Nm ³
No _x @ 13% O ₂ :		101 mg/Nm ³
Efficiency:		80%
Energy efficiency index:		107
Energy efficiency class:		A+
Nominal output:		9 kW
Chimney temperature EN 13229:		213 °C
Temperature in connecting piece:		280 °C
Amount of smoke:		9,5 g/sek
Sub-pressure EN 13229:		12 Pa
Recommended sub-pressure in connecting piece:		16-20 Pa
Required combustion air supply:		25,9 Nm ³ /h
Fuel:		Wood
Fuel consumption:		2,8 Kg/h
Amount of fuel:		2,3 kg

Intermittent fuelling means normal use of a woodstove. In other words, you should let the fire die down until only the embers are left, before refuelling.

The Scan DSA 12 was build in compliance with the homologized product type specified in the Assembly- and Instructions Manual provided with the product.

The DoP declaration of conformity is available from scan.dk



Dimension sketch for Scan DSA 12

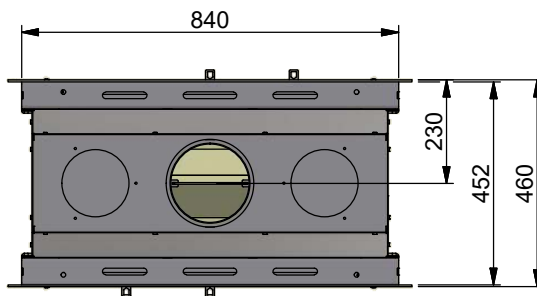
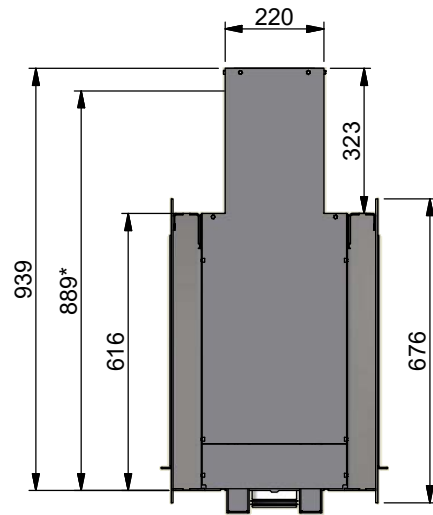
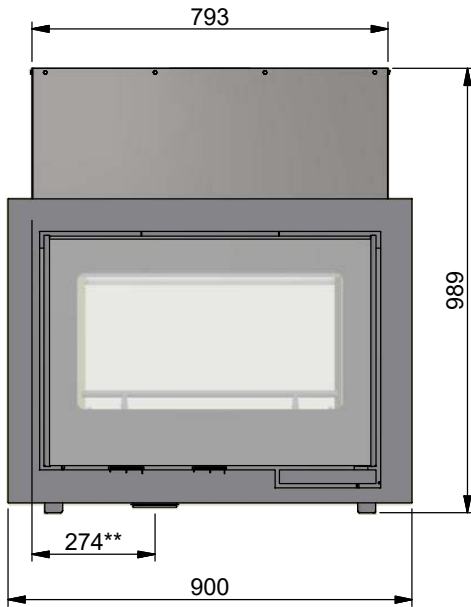

* Height to the beginning of the flue pipe at top outlet

** Centre for inlet of external combustion air bottom

Type plate

All Scan wood-burning stoves are fitted with a type plate, that specifies the approval standards and the distance to flammable materials.

Scan DSA 12		CE	
Insert fired by solid fuel			
Standard:		EN 13229	EC no. 90085600
Minimum distance to heat insulation: Side: 40 mm - Top: 200 mm - Bottom: 0 mm Minimum insulation: Side: 100 mm - Top: 120 mm - Bottom: 60 mm			
CO emission at 13% O ₂ :	0,09%	1142 mg/Nm ³	
Dust at 13% O ₂ :		31 mg/Nm ³	
Flue gas temperature:		280°C	
Nominal heat output:		9 kW	
Efficiency:		80%	
Fuel type:		Wood	
Operation type:		Intermittent	
The appliance can be operated in a shared flue.			
Country	Classification	Certificate/Standard	Approved by
EUR	Intermittent	EN 13229	RWE Power AG
Norway	Klasse 2	SINTEF 110-0327	SINTEF - NBL
Austria		15 a B-VG	RWE Power AG
Schweiz	LRV 11	VKF Nr. 20991	RWE Power AG
Germany	BStV 1	FSPS-Wa 1929-EN	RWE Power AG
Angaben für Österreich			
Wärmeleistungsbereich:		3,9 - 9,7 kW	
Brennstoffwärmeleistung:		12 kW	
Zulässige Brennstoffe:		Scheitholz	
Prüfbericht:		FSPS-Wa 1929-A	
Follow assembly- and instructions manual. Use only recommended fuels. Montage- und Bedienungsanleitung beachten. Verwenden Sie nur empfohlene Brennstoffe.			
1000	Scan A/S	DK 5492 Vissenbjerg	01-2012

Product registration number

All wood-burning stoves are provided with a product registration number.

Please make a note of this number on the front page as you will always have to state it when contacting your dealer or Scan A/S.

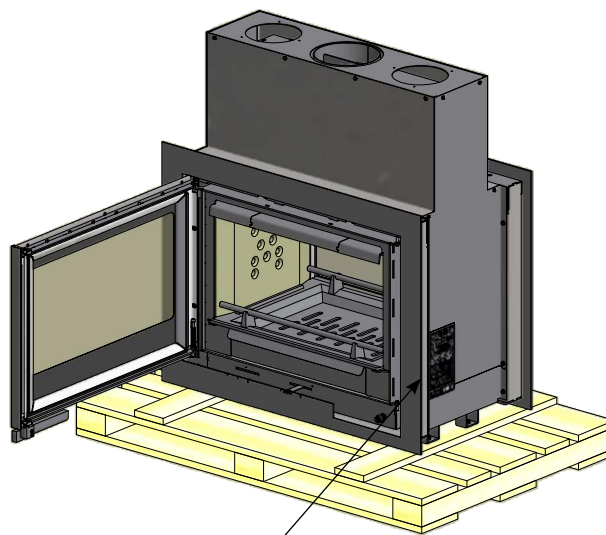

Product registration number

Additional accessories

- Convection adaptors Ø149 mm
- Convection grate 892 x 114 mm

Dismantling

The Scan DSA 12 is supplied attached to a pallet. It is recommended that you remove both doors and trims before unscrewing the stove from the pallet. This makes it easier to install the stove.

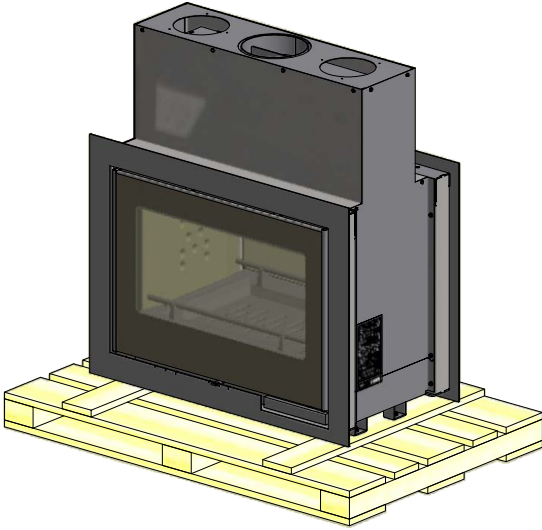

To remove the doors:

Loosen the pointed screw, remove the screw and spring and lift off the door.

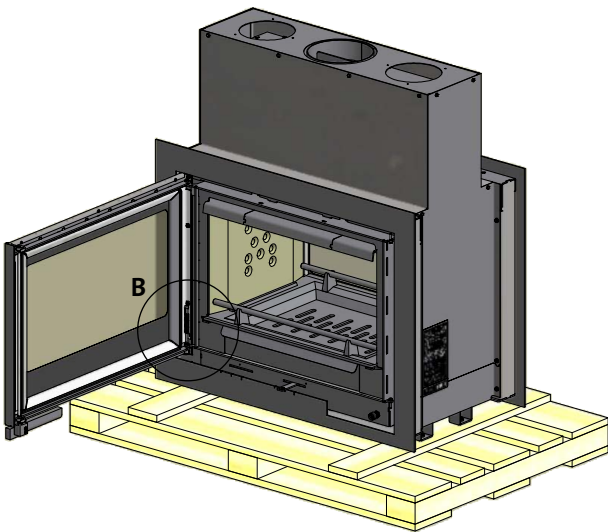

B

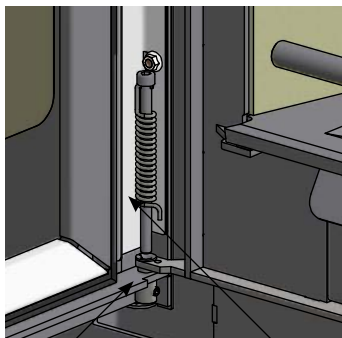

Pointed screw

Screw and spring

Removing the trims:

Remove the flange nuts and lift off the trims.

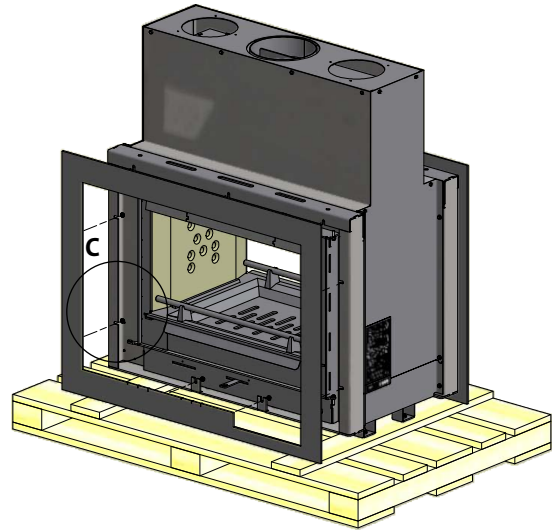

C

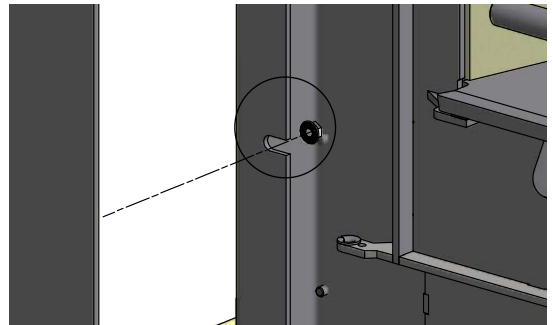

9 x flange nuts M5, which are removed

Important! If you have chosen to fit the built-in stove with convection adaptors, go to page 12

Before installing the stove

Load-bearing foundation

All items in our product range come under the category of light-weight fireplaces and stoves and do not normally require any reinforcement of the beam structure. They can be positioned on ordinary beams/floor.

You should of course make sure that the foundation on which the stove is positioned can indeed support the weight of the stove and, where applicable, a steel chimney, if you have opted for this solution. In case of doubt about the carrying capacity of the floor, please consult a building expert.

Floor plate

The national and local building regulations must be followed regarding the size of a non-flammable base which is to cover the floor in front of the built-in stove.

Your local Scan dealer can give guidance on the rules concerning the protection of flammable material around the stove.

The floor plate's function is to protect flooring and flammable material against any embers.

A floor plate can be made of steel or glass, however clinker tiles, natural stone or similar materials can also be used.

If you have chosen to install the Scan DSA 12 on flammable material, it is a legal requirement that steel floor plates be used on both sides of the stove. One door can be locked, and in such cases a steel floor plate need only be installed on the side on which the door can be opened.

Convection air

Holes for convection air must be made in the surround. Convection means that air circulation occurs, so that the heat is distributed more evenly around the room.

It is advisable to make holes for convection on both sides of the surround.

You must ensure that the requirements for convection areas are met.

Area for convection air in: 350 cm²

Area for convection air out: 500 cm²

If insufficient convection is created, the surround may be damaged.

Distance to furniture: 1200 mm

But please check to avoid furniture or other furnishings being dried out due to being too close to the stove.

Installation in connection with flammable materials

See pages 9 and 10.

Positioning near non-flammable materials

When building or fitting into structures that do not contain flammable materials, a minimum distance of 10 mm must be maintained between the brickwork and the convection hood. This is to prevent cracks in the brickwork caused by the expansion of the metal while the stove is heating. This construction does not require convection grates except for the convection air produced by the convection box of the insert. However, please note that without convection grates, the effect of the insert will be lower.

Trims and doors

Trims and doors are fitted when the surfaces of the surround have been treated.

Ash drawer

Note! The ash drawer can only be used from one side. The door on the opposite side of the ash drawer can be locked.

Existing chimney and pre-fabricated element chimney

If you intend to connect your stove to an existing chimney, it makes sense to contact an authorised Scan dealer, or a local chimney sweep for advice. These experts will also let you know if your flue needs renovating.

When connecting a pre-fabricated element chimney, follow the manufacturer's connection instructions for the relevant chimney type.

Connection between stove and steel chimney

Your Scan dealer, or local chimney sweep, can advise you on choosing a make and type of steel chimney. This ensures that the chimney will match your wood-burning stove. We recommend that the chimney's length from the top of the stove should be no less than 4.5 metres. Some weather or installation conditions might require another length.

Choosing the wrong length or diameter of steel chimney could impair functionality.

Always observe the chimney vendor's instructions precisely.

Requirements for chimney

The chimney must be labelled T400 and G for soot testing.

If the chimney is installed as an extension of the stove and has a length of at least 4.5 metres, a 6" chimney can be used.

If the stove is installed with elbow pipes or other bends in the chimney, a 7" chimney can be used.

The use of a curved elbow pipe is recommended, as it will give a better draught.

If you are connecting your stove using a sharp elbow bend, the clean-out door should be in the vertical section, such that the horizontal part can be cleaned through it.

Safety distance

European, national and local regulations concerning safety distances for wood-burning stoves and flue pipes must be complied with.

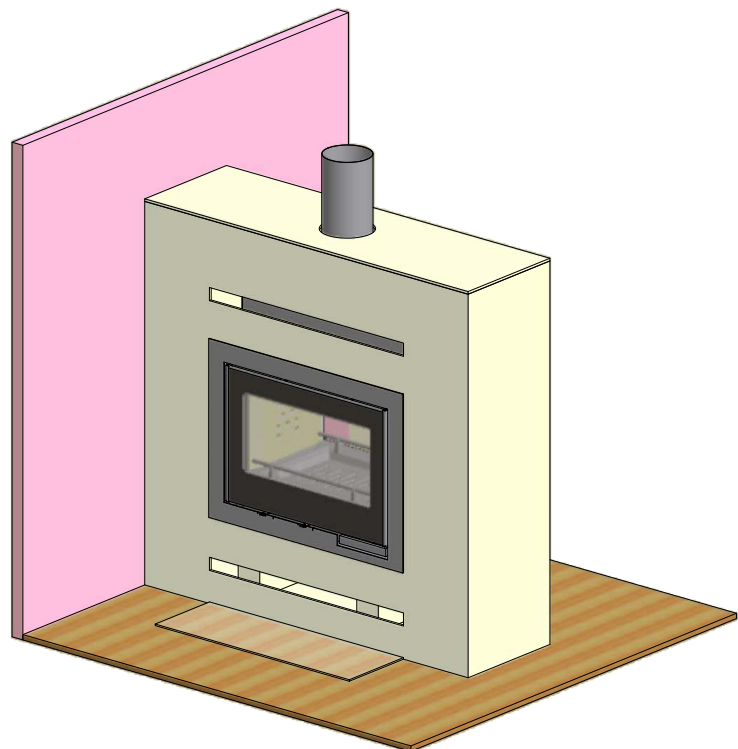

Adjustable supporting legs

The Scan DSA 12 is supplied with adjustable supporting legs. These legs should be considered as providing an auxiliary function and can be used during construction if desired. On completion of installation, the stove must stand on the side pieces.

To adjust the height of the legs, the bottom part of the stove side plates should be loosened and bent. When the plates are bent, they can break off. This is not a fault. They can be screwed back on when you have finished using the supporting function.

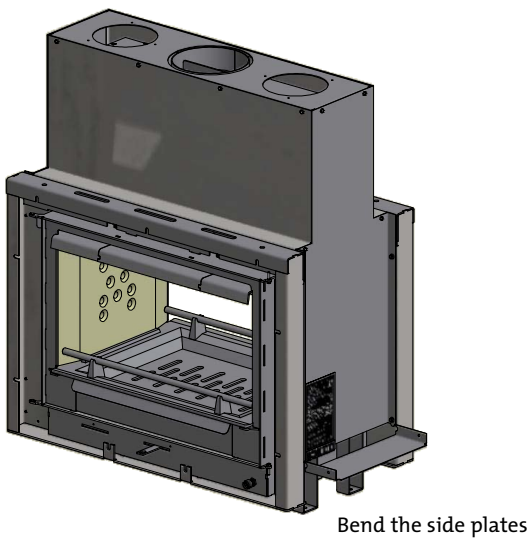
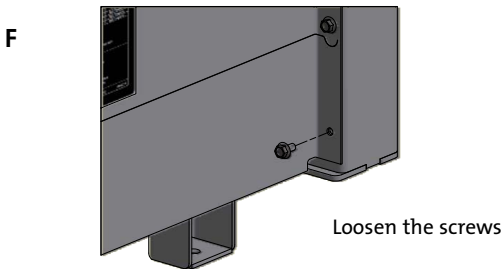
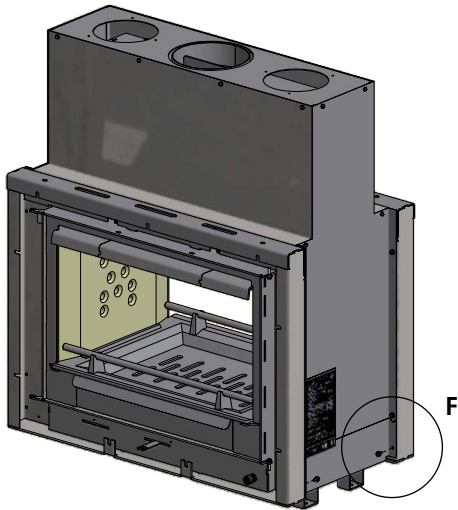

When the supporting legs are in their highest position, the stove will be 1388.6 mm tall. When they are at the bottom, the stove will be 989 mm tall.

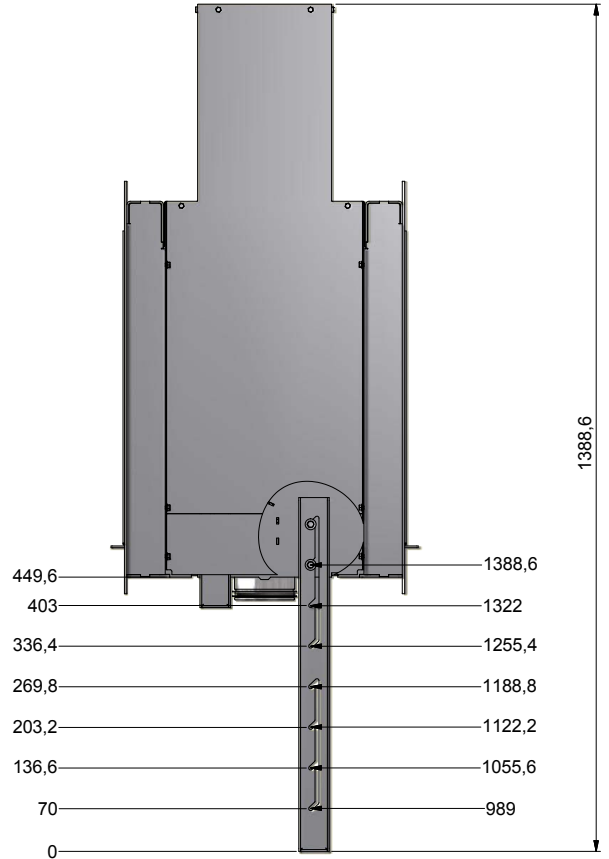

Base of Scan DSA 12

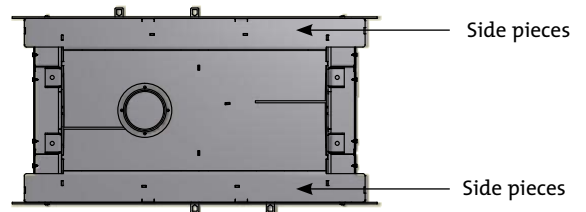

Installation in connection with flammable materials

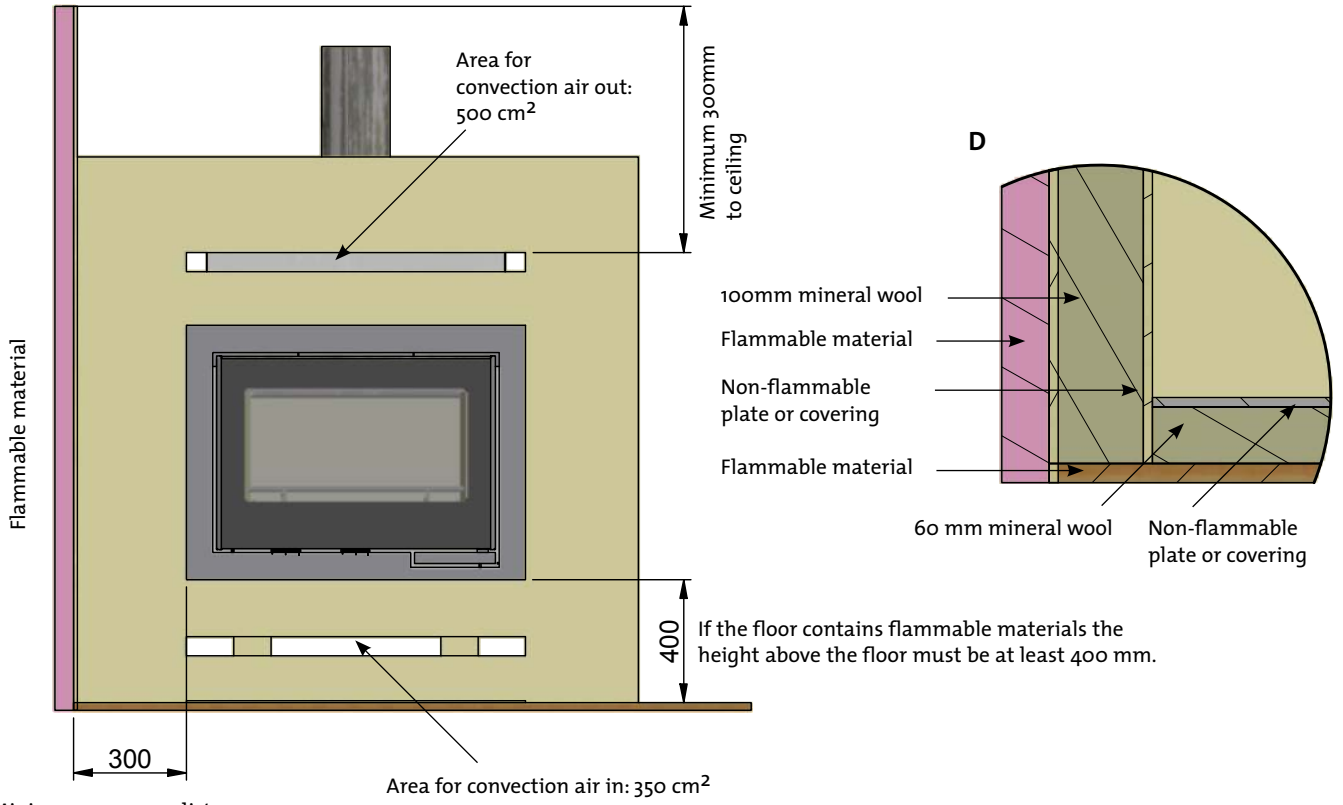

Minimum 300 mm distance to flammable materials
 Minimum 120 mm distance to non-flammable materials

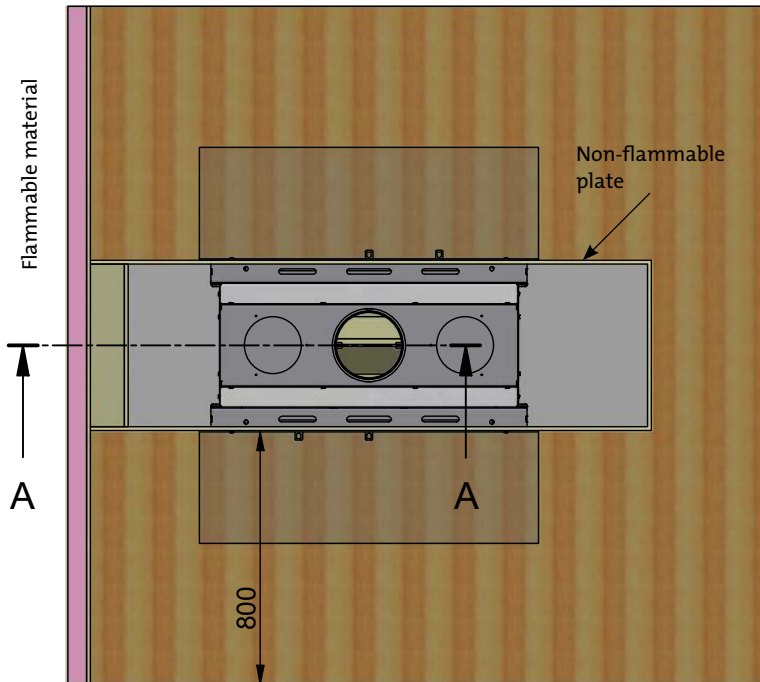

Minimum 800 mm distance to non-flammable materials

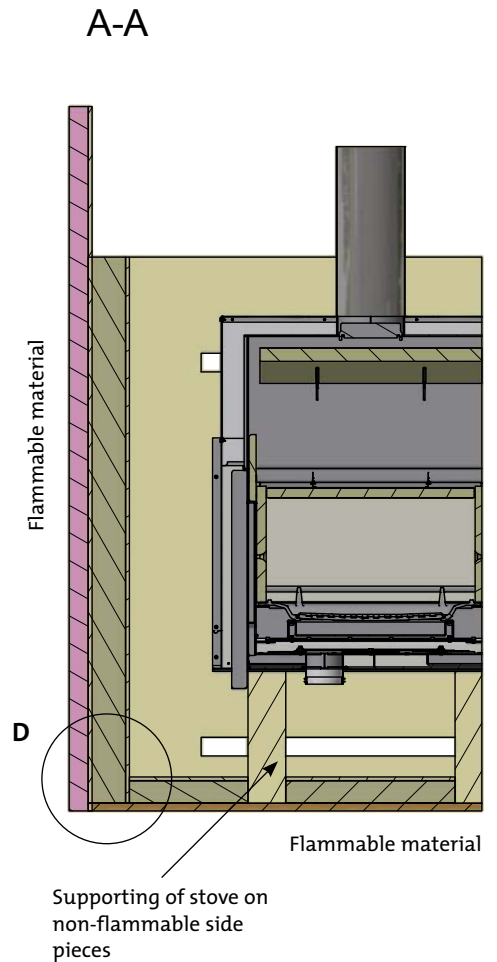

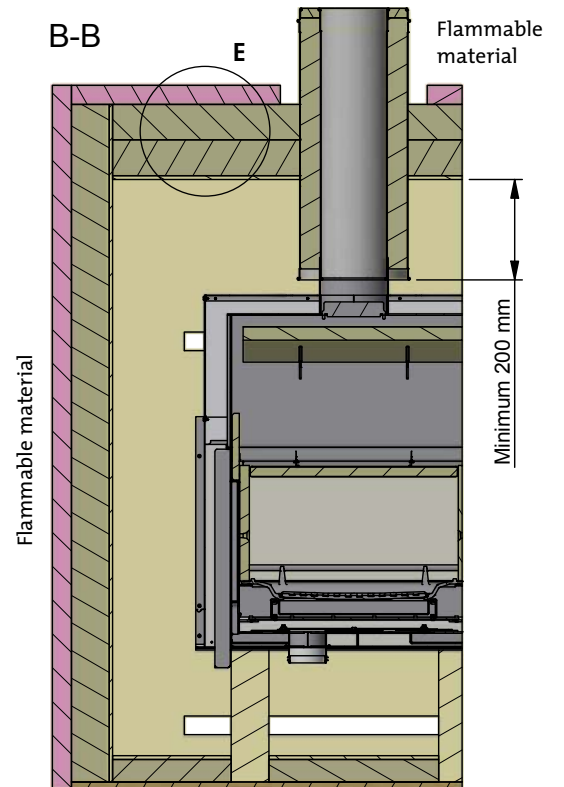
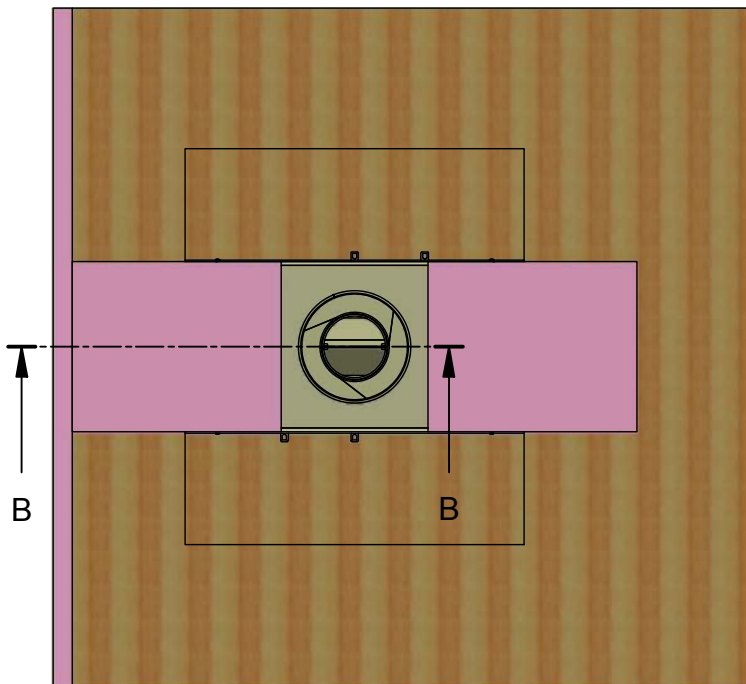
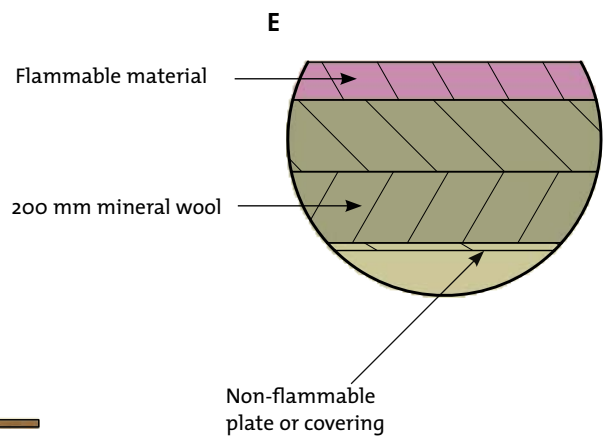
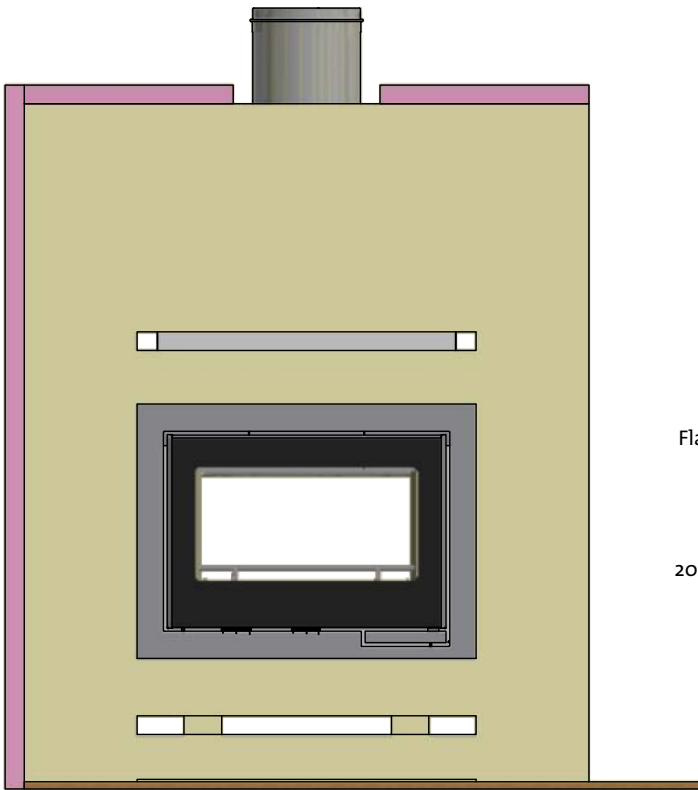

Door lock

The door on the opposite side of the ash drawer can be locked. This is done while the door is closed. Use the allen key from the service kit provided.

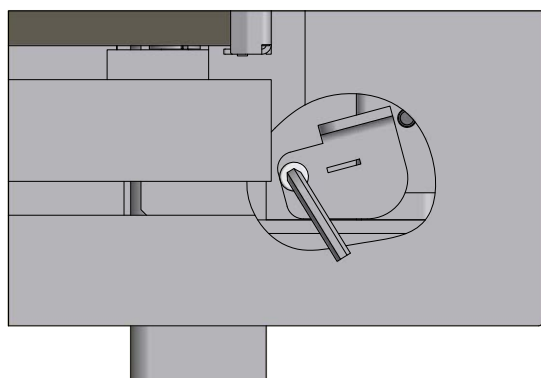
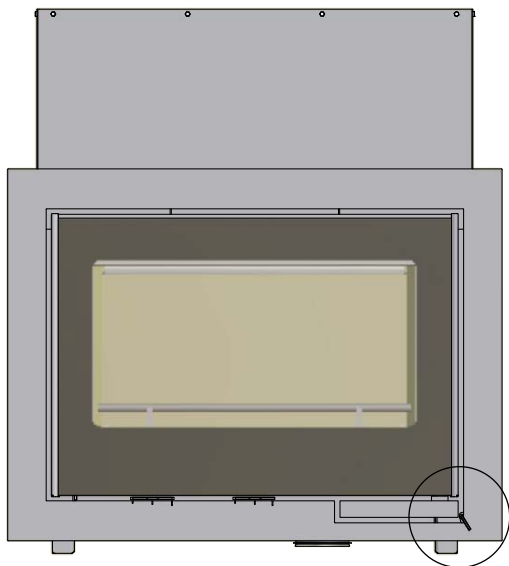

Tilt the lock to the left and tighten.

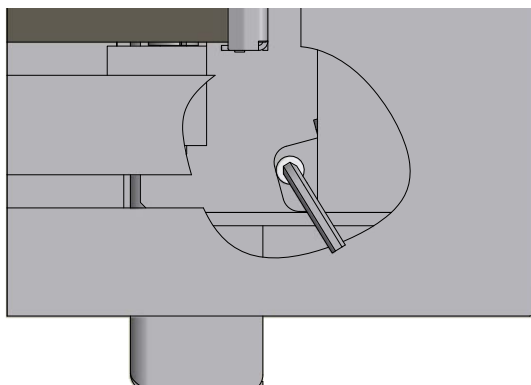

Fresh air intake

In a well-insulated house, the air used up by the burning process has to be replaced. This particularly applies to houses with mechanical ventilation. There are different ways of making sure that an air exchange takes place. The most important thing is to ensure that there is a supply of air to the room where the wood stove is located. The external wall vent must be located as close to the wood stove as possible, and you must be able to close it when you are not using the wood stove.

National and local building regulations must be followed with regard to the connection of fresh-air intake.

Closed combustion system

You should use the closed combustion system for the wood-burning stove if you live in a newly-built, airtight home. Outside air for combustion is connected through a ventilation pipe via the wall or floor.

We recommend mounting a valve in the ventilation pipe in order to avoid condensate in the stove and the pipe system, which can be closed when the oven is not in use. It can also be an advantage to insulate the ventilation pipe.

Minimum \varnothing 100 mm ventilation pipe, maximum length: 6 metres with a maximum of one bend. We recommend smooth steel pipes.

External combustion air can be connected to the connection piece underneath the combustion chamber.

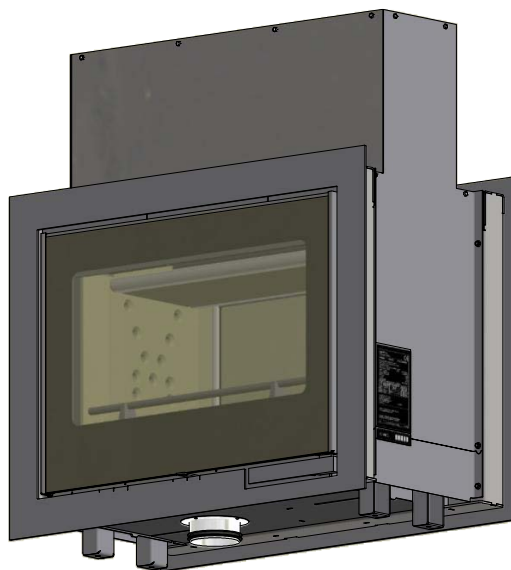

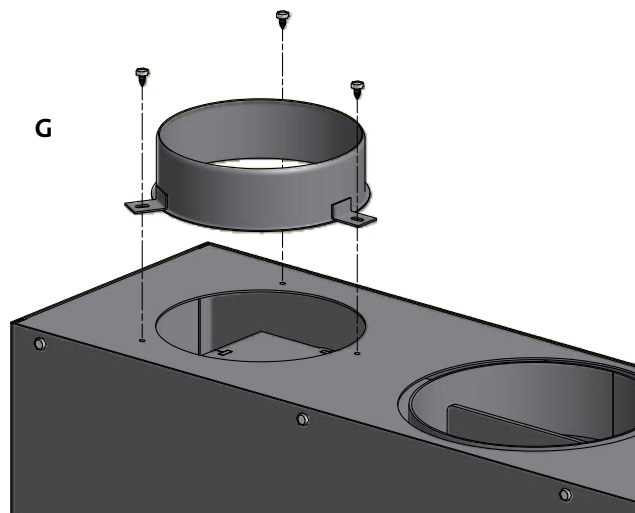
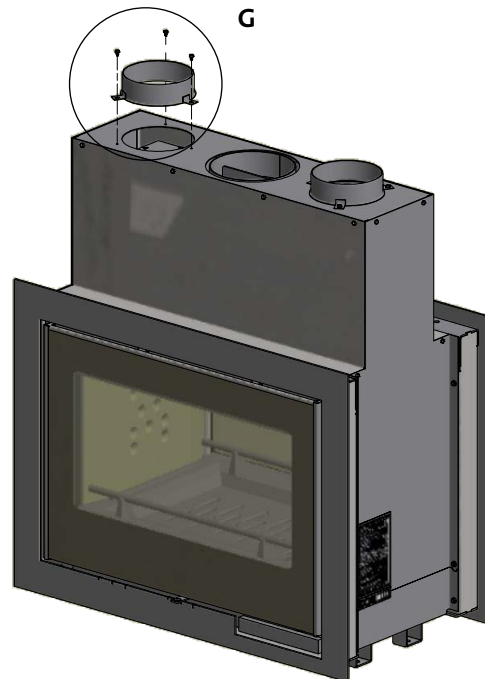
Fitting the convection adaptors

6 x hexagonal screws M 4.8 x 9.5

Mounting of convection grate

Available in black and white.

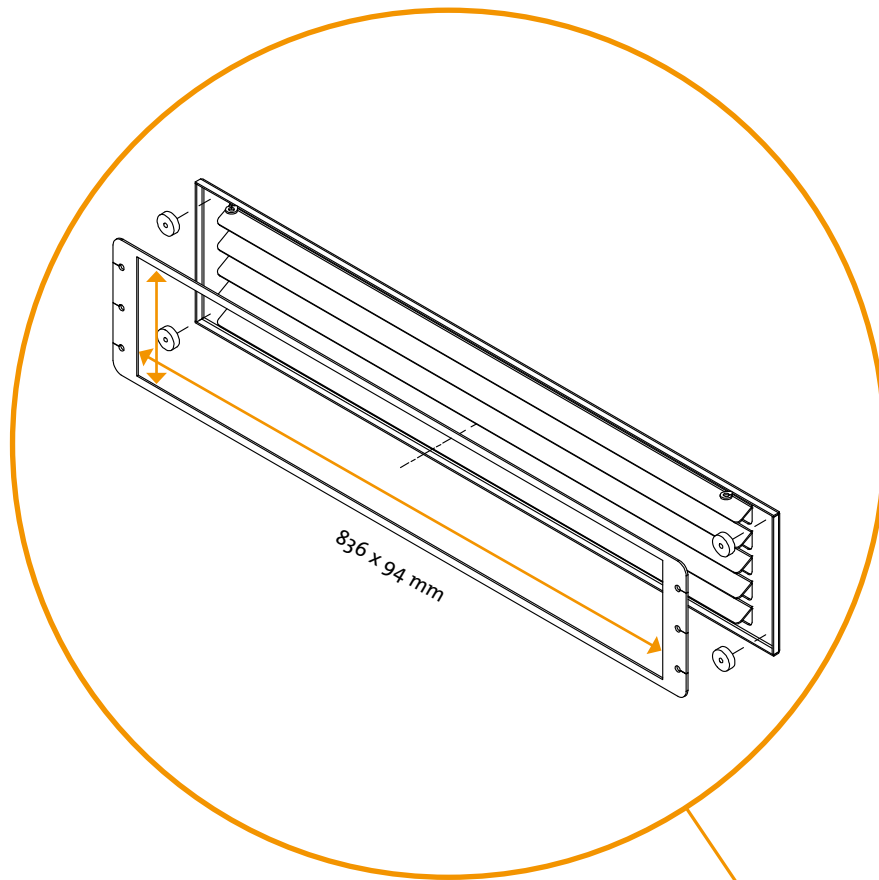

1

Cut a hole in the wall according to the indicated measures

2

Mount the metal frame

3

Place the four magnets on each side of the metal frame and then mount the convection grates on the magnets

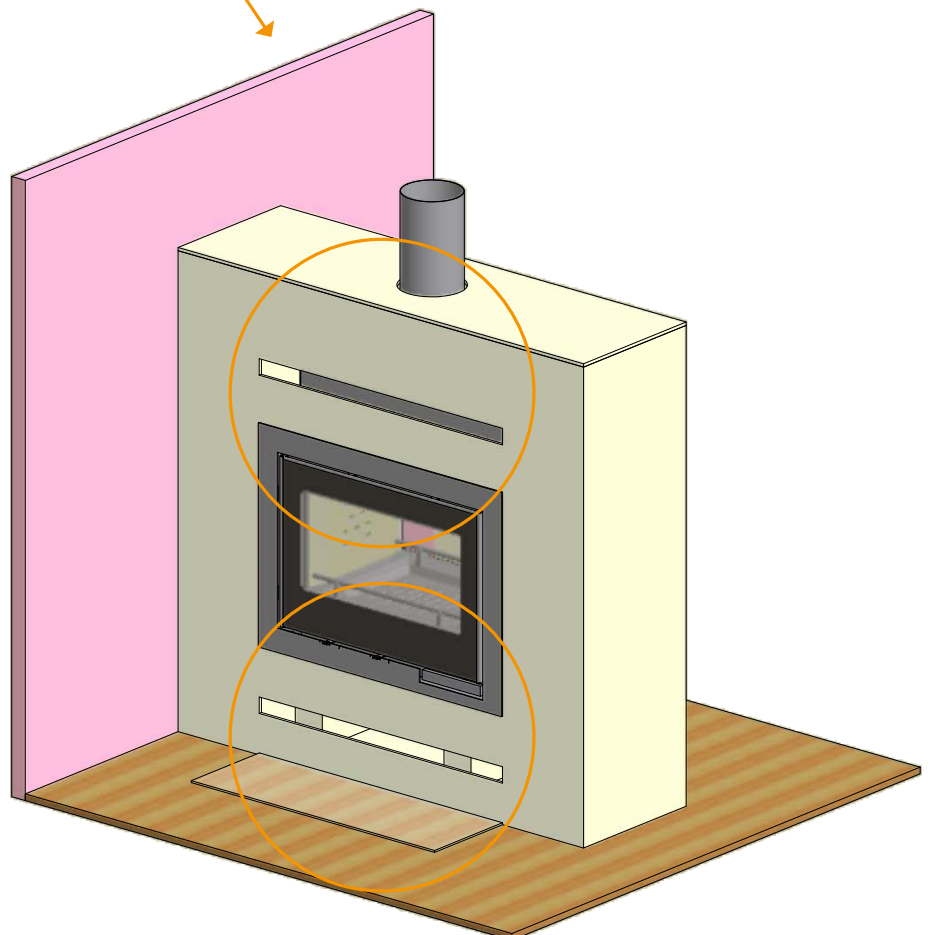

CB-technique (Clean Burning)

The stove is equipped with the clean burning technique. In order to ensure an optimal combustion of released gases under the incineration process, air will pass through a specially developed canal system. The heated air is led into the combustion chamber through the small holes at the rear of the burn chamber.

This air volume is controlled by the combustion rate and thus cannot be regulated.

NOTE: The wood must never be placed higher than the tertiary holes at the rear of the burn chamber (This does not apply at a cold start).

Lower baffle plate

The baffle plate is placed in the upper part of the combustion chamber. This plate will block the smoke and give it a longer holding time in the combustion chamber before it goes up the chimney. The temperature of the flue gases will decrease because it has more time to release heat from the stove. When sweeping, remove the smoke deflector plate and read the "Stove maintenance" section. Be aware that the baffle plates are made from a porous chemical material which can break easily. You must therefore take care when handling them. The baffle plates are wearing components and do not entail a right to claim.

Primary air

The primary air regulation mechanism is used for lighting the fire, or to boost the burning process when you put wood on. The primary air vent can be 0-50% open if you use hard wood fuel such as oak and beech. You can close the primary air vent if you use soft wood such as birch or pine for fuel.

Settings for normal load: 0 - 50%

Secondary air

Secondary air is pre-heated and fed indirectly to the fire. At the same time, the secondary airflow cleans the glass pane to avoid soot build-up. If you over-restrict the secondary airflow, soot can build up on the glass pane. The secondary airflow determines the heat output from your wood stove.

Settings for normal load: 40 - 70%

Ash drawer

Open the glass door to access the ash drawer which is located below the combustion chamber.

Keep the ash drawer closed at all times when the wood stove is lit.

The ash drawer must not be overfilled and must therefore be emptied at regular intervals.

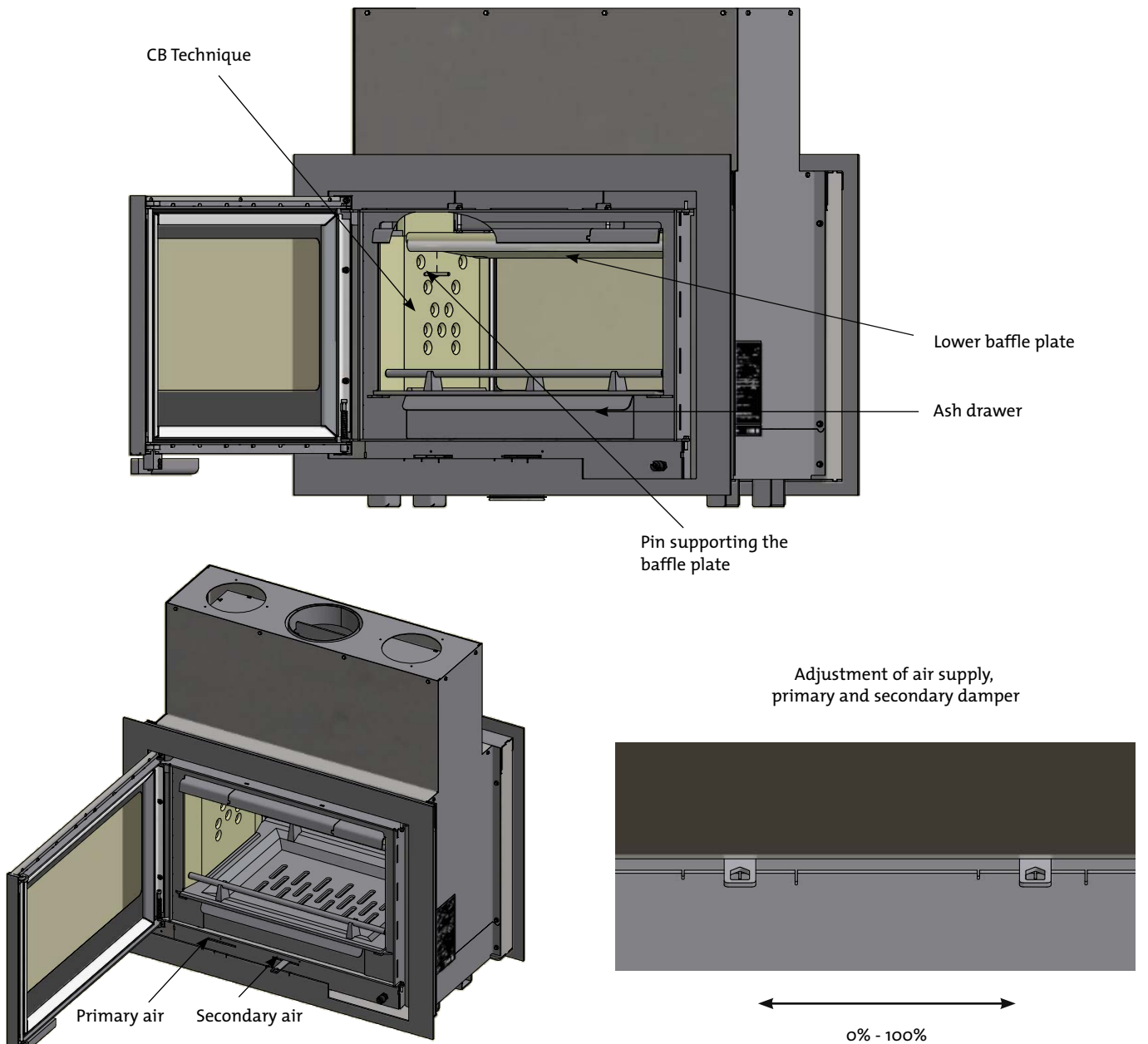

Environmentally-Friendly Heating

Avoid restricting your wood-burning stove to an extent where no flames are visible during the degasifying period, as this leads to particularly inefficient heating. The gases released by the wood do not burn due to the low temperature in the combustion chamber. Part of the gas condenses in the wood-burning stove and flue system as soot, and this could lead to your chimney catching fire. The smoke that exits the chimney is bad for the environment and has an unpleasant smell.

Lighting

We recommend the use of fire starters, or similar products, which are available from your Scan dealer. Using fire starters helps to light the wood quicker, and keeps the burning process clean. Never use liquid lighting fuels!

„Top down“ lighting

"Top down" lighting gives a more environmentally friendly start to your fire and helps to keep the glass area as clean as possible.

3 pieces of wood approx. 35 - 45 cm long with a weight of approx. 1 kg per piece.

1 piece of wood approx. 30 - 35 cm long with a weight of about 0.5 kg.
15 - 25 thin sticks of about 20 cm with a total weight of approx. 500 g.
3 fire starters.

Position the large logs in the centre of the combustion chamber 1-2 cm apart as shown. Put half the kindling sticks across the logs in a criss-cross fashion. Place the smallest log on top of the sticks as shown and arrange the last sticks in front of the log. Position the firestarters between the sticks and light.

Set the primary and secondary air controls to maximum in the lighting phase. If the fire is too strong, you may throttle down the primary air damper (at the left).

Continuous firing

It is important to reach as high a temperature as possible in the combustion chamber. This makes the most efficient use of the wood stove and fuel, and ensures a clean burning process. At the same time, this avoids soot build-up on the combustion chamber walls and glass. While the stove is lit, you should not see any smoke, but just air movement that indicates the burning process.

After completing the lighting phase, you should have a good layer of embers in the wood stove; you can then start stoking up the stove. Lay 2-3 pieces of wood, of about 1 kg weight with a length of about 35 - 45 cm onto the fire.

Note! The wood must catch fire quickly; this is why we recommend setting the primary airflow to full power. Running the stove at too low a temperature and with too little primary air can lead to deflagration of the gases, and thus cause damage to the stove.

When stoking up with wood, always open the glass door carefully to avoid smoke escaping. Stoke up with wood while the fire is still burning nicely.

Using your stove in the spring or autumn

Occasional lighting of the stove using the „top down“ lighting method (see above) is recommended in changeable weather such as in spring/autumn when your heating requirements are not as great.

Why you need a chimney

The chimney is the wood-burning stove's motor; it's performance decides how well your stove will work. The draft in the chimney creates a vacuum in the wood-burning stove. The vacuum draws the smoke out of the stove, and takes in air through the combustion air baffle to fuel the burning process. Combustion air is also used for the airwash system that keeps the window clear of soot.

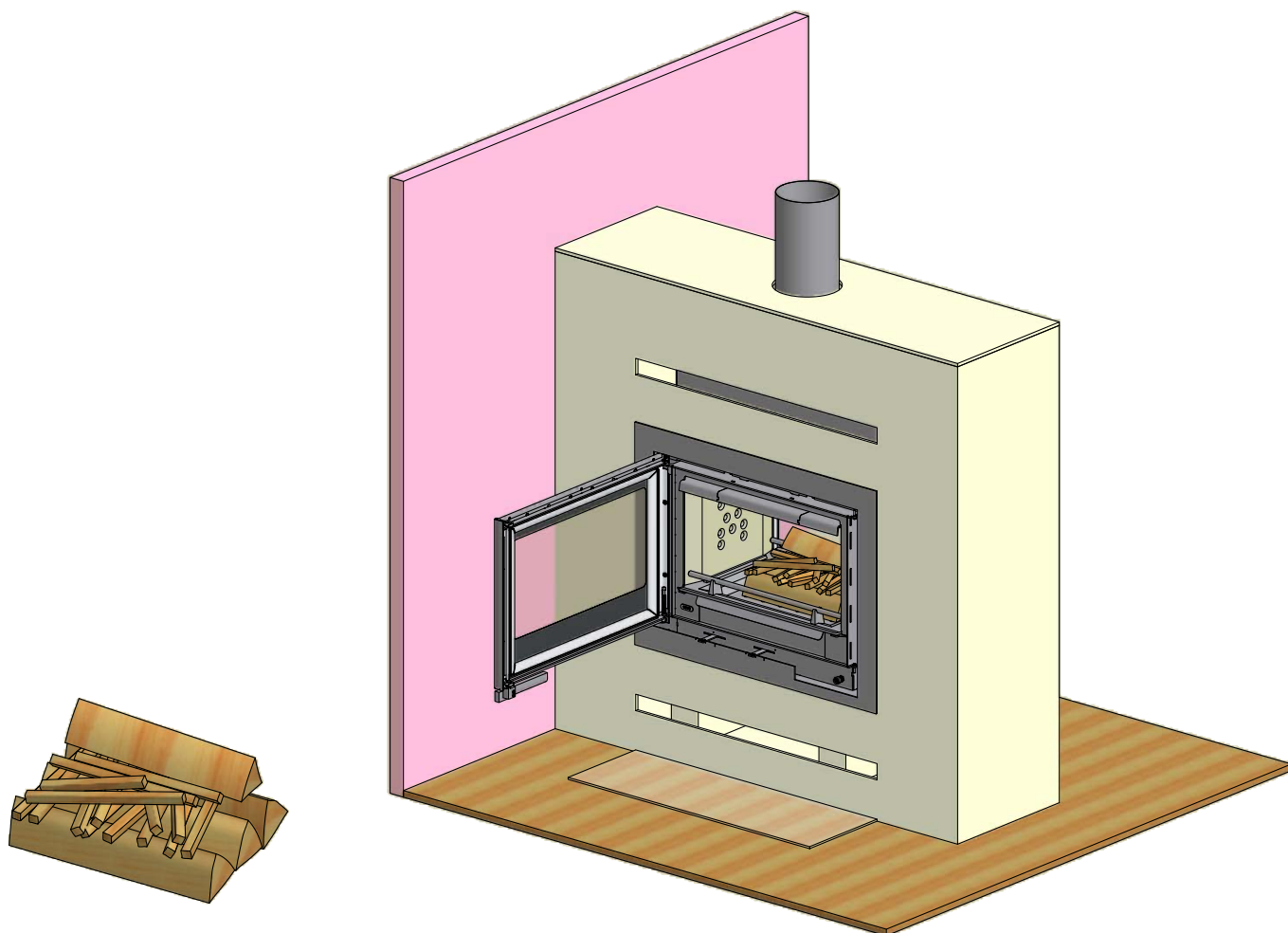

The draft in the chimney is caused by the difference in temperatures inside and outside the chimney. The higher the temperature difference is, the better the draft in the chimney will be. It is thus important for the chimney to reach operating temperature before you adjust the damper to restrict combustion in the stove (a brickwork chimney will take longer to reach operating temperature than a steel chimney). It is very important to reach operating temperature as quickly as possible on days on which the draft in the chimney is poor due to unfavorable wind and weather conditions. Make sure the fuel ignites as quickly as possible (with visible flames). Chop the wood into particularly small pieces; use an extra fire lighter etc.

After longer periods of disuse, check the chimney flue for blockage. You can connect several units to the same chimney. But make sure check with your chimney sweep to observe local regulations.

No matter how good your chimney is, it will not perform well if you do not use it correctly. On the other hand a poor chimney, may give you acceptable results if you use it correctly.

Using your stove in various weather conditions

Wind blowing on the chimney can have a great effect on how your stove reacts in various wind conditions; you may need to adjust the airflow to achieve good burning results. Fitting a damper in the flue pipe may also help as it will give you the ability to regulate the draught in changing wind conditions.

Fog can also have a great influence on how well a chimney draws; you may again need to adjust the airflow settings to achieve good burning results.

General Notes

Your wood stove is not designed for continual heating for periods of over 24 hours.

Please note! Parts of the wood-burning stove, especially the outer surfaces, become hot during use. Please exercise due care.

Never empty the combustion chamber completely of ash. The fire will burn best with an ash layer of approx. 20mm.

Never empty ashes into a flammable container. Ashes can contain glowing embers long after you finish using your wood stove.

While the stove is not in use you can close the baffle to avoid drafts through the stove.

After longer breaks you should check the smoke outlet paths for blockages before lighting.

Chimney fires

In case of a chimney fire, keep the stove door, the ash drawer, and all the valves on the stove closed. In case of emergency, call the fire service.

Handling fuels

Selecting Wood/Fuel

You can use any type of wood as firewood, however, harder types, such as beech, ash, are generally better for heating as they burn more evenly and create less ash. Other wood types like maple, birch and spruce are excellent alternatives.

Handling

Firewood is best if you fell the tree, and saw and split the wood, before May 1st. Remember to cut the logs to match the size of your wood-burning stove's combustion chamber. We recommend a diameter of 6-10 cm. The length should be about 6 cm shorter than that of the combustion chamber to leave enough space for air to circulate. Firewood with a greater diameter needs splitting. Split wood dries faster.

Storing

You need to store the sawn and split firewood in a dry place for 1-2 years before burning. Wood dries faster if you stack it in an airy place. Before use, store the firewood for a few days at room temperature. Note that wood absorbs moisture during the autumn and winter seasons.

Moisture

To avoid environmental issues, and for optimum burning, wood has to be perfectly dry to be suitable for use as firewood. The max. residual moisture in the wood should not exceed 21%. A moisture content of 15-18% yields best results. As an easy way of checking if wood is dry, just knock two pieces of wood together. If the wood is moist, the sound will be dull.

If you use damp wood, most of the heat it produces will be used to evaporate the water. The temperature in the wood stove does not rise, and the room is not sufficiently heated. Of course, this is not economical, and it will cause soot build up on the glass pane, in the stove, and in the chimney. Burning moist wood also causes pollution.

Understanding units for measuring wood

Various units of measurement are used for wood. Before you buy wood, it makes sense to familiarise yourself with the terms. There are various brochures, in public libraries for example, that cover this topic.

Materials which cannot be burned

Painted, pressure impregnated, or glued wood, driftwood from the sea. Never burn chipboard, plastics, or chemically treated paper. These materials are dangerous to humans, to the environment, your wood stove, and your chimney. To keep a long story short – make sure you burn only quality firewood.

Firewood fuel value

The fuel value is different for different types of wood. In other words, you need to use more wood of certain types to achieve the same heating performance. This Instruction Manual assumes that you will be using beech, which has a very high fuel value, and is also a wood that is easy to procure. If you use oak or beech wood fuel, note that these wood types have a greater fuel value than, say, birch. Make sure you use less fuel to avoid damage to the wood-burning stove.

Wood types	Kg Dry wood/m ³	Compared to beech
Hornbeam	640	110%
Beech/Oak	580	100%
Ash	570	98%
Maple	540	93%
Birch	510	88%
Pine	480	83%
Fir	390	67%
Poplar	380	65%

Maintaining your wood-burning stove

Apart from regular chimney sweeping, your wood-burning stove does not require any regular maintenance.

Use only original replacement parts for maintenance and repairs of your stove.

Note! Make sure the stove is cold before starting maintenance or repair work.

Coated surfaces

Clean your wood-burning stove by dusting with a dry, lint-free cloth. If the topcoat is damaged, you can purchase a repair spray from your authorised Scan dealer. As slight differences in colour are possible, spray a larger area to achieve a natural transition for best results. For best results, apply repair spray when the wood-burning stove is hand-hot.

Cleaning the glass

Our wood-burning stoves are designed to prevent serious soot build up on the glass. The best way to achieve this is to make sure you have a sufficient combustion air supply. It is also important to use dry wood, and have a correctly dimensioned chimney.

Even if you follow all of our instructions, a slight film of soot can build up on the glass. You can easily remove this build up by cleaning with a dry cloth and glass cleaner. Please note that the glass cleaner is not to get into contact with the gaskets, as this can discolour the glass permanently.

Combustion chamber lining

Slight cracks can appear in the combustion chamber lining due to moisture, or to the heating/cooling process. These cracks have no influence on the heating performance or lifetime of your stove. However, if the lining starts to crumble, you must replace it. The combustion chamber lining is not covered by the warranty.

Ceramic gasket

All wood-burning stoves have gaskets made of ceramic material fitted to the stove, the doors, and/or the glass. These gaskets are subject to wear and tear, and must be replaced when necessary. Ceramic gaskets are not covered by the right to claim.

Chimney sweeping and cleaning your wood-burning stove

Follow national and local chimney sweeping regulations. We recommend having the wood-burning stove cleaned regularly by the chimney sweep.

Before starting to clean your wood-burning stove, and sweep the flue pipe, we recommend first removing the smoke deflector plates.

Removing the baffle plates

Be very careful when removing the baffle plates from the stove. Lift the lower baffle plate, remove the pins and take out the plate.

Please note that the lower baffle plate supports the sides of the combustion chamber lining, which could therefore fall when the plate is removed.

In order to remove the upper baffle plates, the combustion chamber lining must be taken out. The baffle plates are lifted from their holder and rotated down and out through the combustion chamber.

Checking the stove

Scan A/S recommends that you check your stove thoroughly after sweeping/cleaning. Check all visible surfaces for cracks. Check that all joints are tight and that the seals sit correctly. Worn or deformed seals should be replaced.

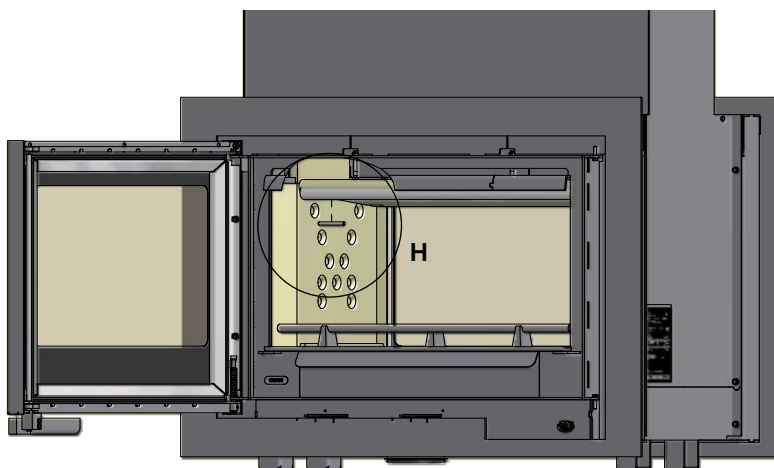

H

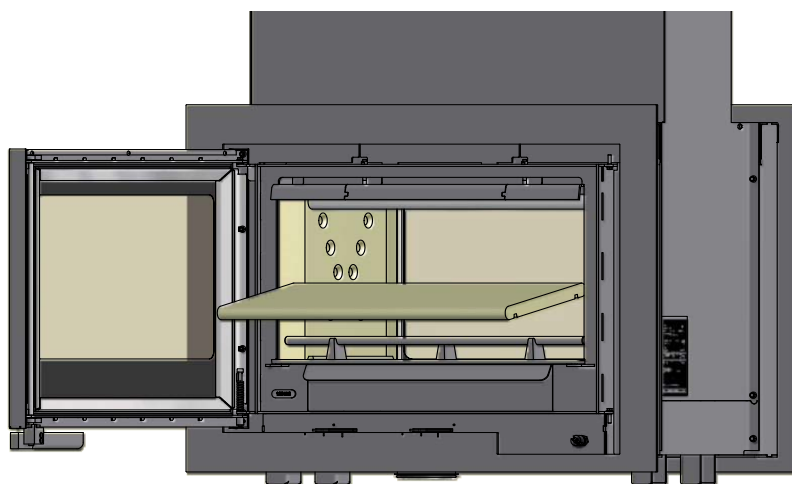
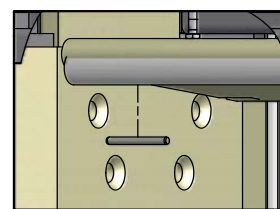

Positioning the baffle plates and combustion chamber sides

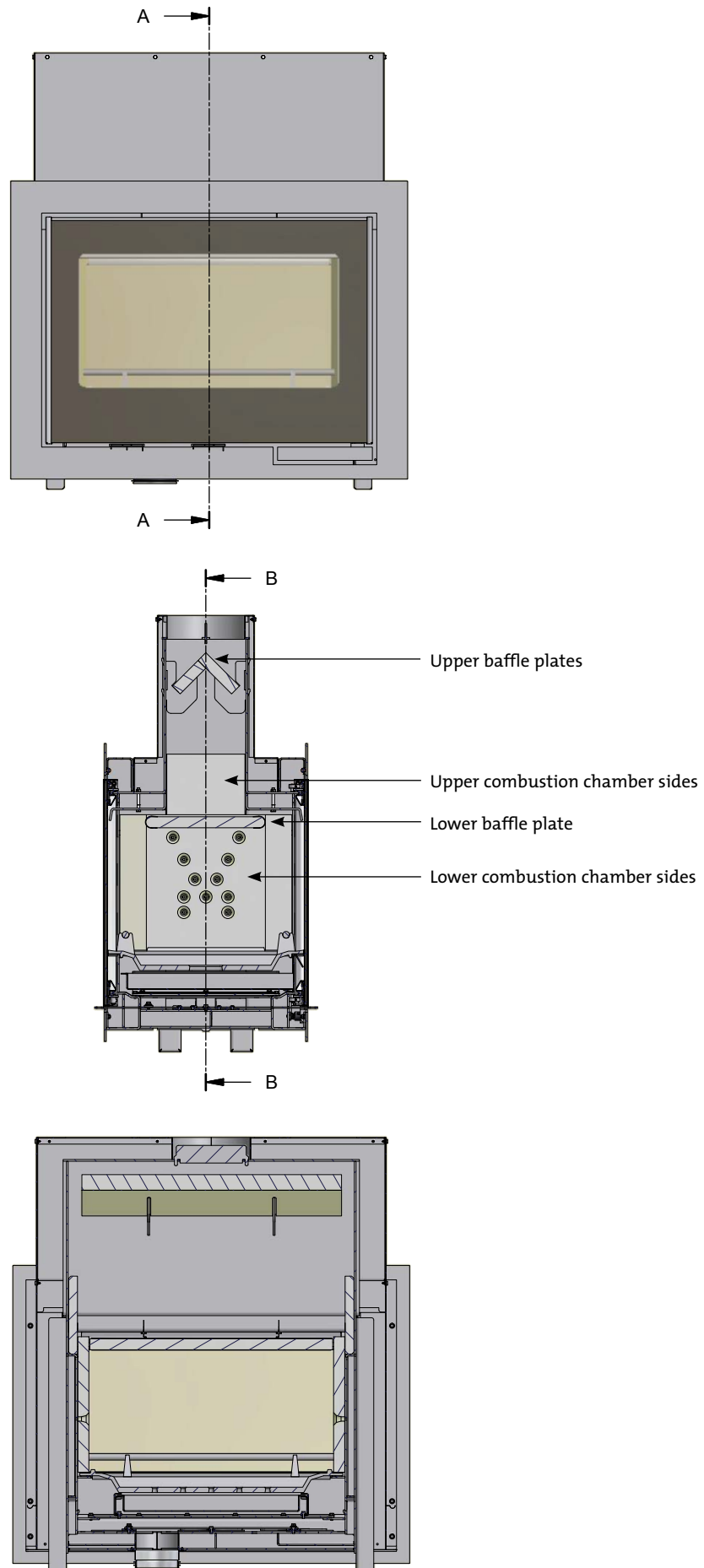

Smoke escaping

- Damp wood
- Chimney not drawing properly
- Chimney is not properly dimensioned for the stove
- Check if the flue pipe/chimney are blocked
- Is the chimney the right height for its surroundings?
- Vacuum in room
- The door is opened before the embers have burned down sufficiently

Wood burning too quickly

- The air valves are set incorrectly
- The baffle plates is incorrectly mounted or missing
- Inferior firewood (waste wood, pallets etc.)
- Chimney too large

Soot build-up on glass

- Incorrect secondary airflow setting
- Excessive primary air
- Damp wood
- Wood pieces too large on lighting
- Inferior firewood (waste wood, pallets etc.)
- Chimney not drawing sufficiently
- Vacuum in room

Excessive soot build-up in chimney

- Poor burning (more air required)
- Damp wood

The surface of the stove is turning grey

- Overheating (see instructions for heating)

Poor heating performance of stove

- Damp wood
- Not enough wood
- Inferior wood quality with low fuel value
- Smoke deflector plates are not fitted correctly

Odour coming from stove

- The lacquer on the stove hardens when you use the stove for the first time; this can cause an odour. Open a window or a door for ventilation, and make sure the stove is heated up sufficiently to avoid odours later.
- When heating up and cooling down, the stove may make some clicking noises. These are due to the huge temperature differences to which the material is exposed and do not indicate any product defects.

Warranty

All wood-fired Scan products are made of high-quality materials and subject to strict quality controls before leaving the factory. We give a warranty of 5 years on manufacturing errors or defects.

You must quote your stove's product registration number when you contact us or your authorised Scan dealer with a warranty claim.

The warranty covers all parts which in the opinion of Scan A/S require repair or replacement due to manufacturing or construction error

The warranty applies to the original purchaser of the product only, and is not transferable (except on prior sale).

The warranty covers only damage caused by manufacturing or construction errors.

The following parts are not covered by the warranty

- Wear and tear parts, such as the combustion chamber liners, smoke deflector plates, shaker grate, glass, tiles, and seals (except for defects which were present on delivery).
- Defects caused by external chemical and physical influences during transportation, storage and assembly, or at a later time.
- Soot build-up caused by poor chimney draught, damp wood, or improper use.
- Costs of additional heating in connection with a repair.
- Transport costs.
- Costs for setting up, removing the wood stove.

This warranty is void

- In case of incorrect installation (the installer is responsible for observing and complying with legal requirements and local bylaws, along with this Assembly- and Instructions manual for the wood-burning stove and accessories).
- In case of improper use, and/or use of prohibited fuels, non-original spares (see this Assembly- and instructions manual).
- If the product registration number of the stove has been removed or damaged.
- In case of repairs that do not comply with our instructions or instructions by an authorised Scan dealer.
- In case of any manipulation of the original state of this Scan product or its accessories.
- This warranty is only valid in the country to which this Scan product was originally supplied.

Always use original replacement parts, or parts recommended by the manufacturer.

Version

UK 90085500-6

29.01.2018

Scan A/S - DK-5492 Vissenbjerg

